

Little Folks

- FURNITURE -



Classic Bunk Bed

Code: BBD010

PLEASE READ CAREFULLY & KEEP FOR FUTURE REFERENCE

Thank you for buying a **Little Folks** piece of furniture

Treated properly it should be a faithful servant for years - and we hope you get the same amount of pleasure from it. Before you do

- please take a few minutes to read these instructions
- we suggest you carefully unpack everything, lay it out on a clean, flat floor and identify everything on the parts list in these instructions. Do not throw away any packaging until you are sure you have all the parts.

If you have any problems assembling the product please call our customer services on 01985 300588 and we will try and help. If for any reason you wish to return the product, you must disassemble the product and pack in the original packaging.

Taking care of your product

Your furniture should require no more than a regular dust off with a soft cloth. If the furniture is not painted then a superior wood polish can be used - but never use polishes containing silicone.

If necessary it can be cleaned with a damp cloth with a mild detergent solution - and then dried with a lint-free cloth. Never clean with abrasives or chemical cleaners.

Direct sunlight or heat from a radiator can stain, discolour warp or crack furniture.

We know furniture can be heavy but try not to drag furniture across the floor as this can damage it.

PRODUCT SAFETY

This product is designed to conform to BSEN747:1 2012+A1:2015

The MAXIMUM thickness of the UPPER BUNK mattress is 20cm.

The recommended size of the mattress is 190cm x 91cm (6'3" x 3'0")

Periodically check that all assembly fixings are tightened properly, care should be taken to ensure that no fittings are loose.

Always follow the manufacture's instructions.

Please ensure that good ventilation is maintained within the room in order to keep humidity low and to prevent mould in and around the bed;

WARNING "High beds and the upper bed of bunk beds are not suitable for children under six years due to the risk injury from falls".

WARNING "Bunk beds and high beds can present a serious risk of injury from strangulation if not used correctly. Never attach or hang items to any part of the bunk bed that are not designed to be used with the bed, for example, but not limited to ropes, strings, cords, hooks, belts and bags"

WARNING "Children can become trapped between the bed and the wall, a roof pitch, the ceiling, adjoining pieces of furniture (e.g. cupboards) and the like. To avoid risk of serious injury the distance between the top safety barrier and the adjoining structure shall not exceed 75mm or shall be more than 230mm.

WARNING Do not use the bunk bed if any structural part is broken or missing;

WARNING Hole covers Not suitable for children under 36 months due to choking hazard.

If you have any problems please do contact us for help on email customerservices@littlefolksfurniture.co.uk or phone our CUSTOMER SERVICES 01985 300588

Parts



1 x upper left mattress rail(hole in rail)



1 x upper right mattress rail(hole in rail)

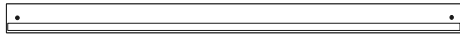

2 x lower bed mattress rails

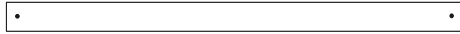

2 x long safety rails

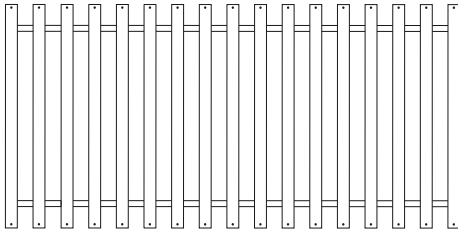

2 x mattress base



2 x front safety rails

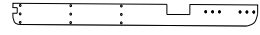

1 x right ladder string

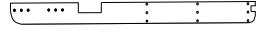

1 x left ladder string



3 x ladder treads

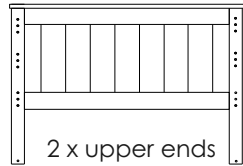

2 x upper ends

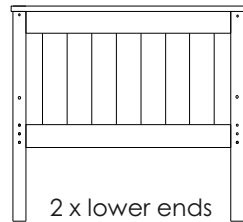

2 x lower ends

Fittings

14 x 9cm Bolts



2 x 7cm Bolts

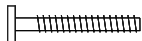

2 x 6cm Bolts



1 x 3.5cm Bolts



7 x 5cm screw bolts

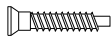

16 x Barrel Nuts



76 x Screws 3.5cm



44 x small Dowels

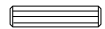

4 x Large Dowels

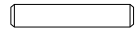

2 x sleeve nuts



Tools Req

Screwdriver

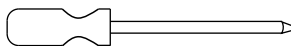

2 x Allen Key



small hammer

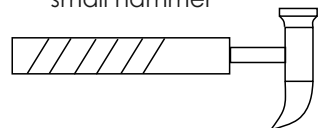

Fitting the mattress and safety rails

32 x small wooden dowels

Insert 2 wooden dowels into each end of each rail. Gently tap dowels inwards until firmly in place.



X 1

1 x upper mattress rail (left)



X 1

1 x upper mattress rail (right)



X 2

2 x lower mattress rails



X 2

2 x long safety rails



X 2

2 x front safety rails

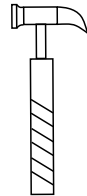
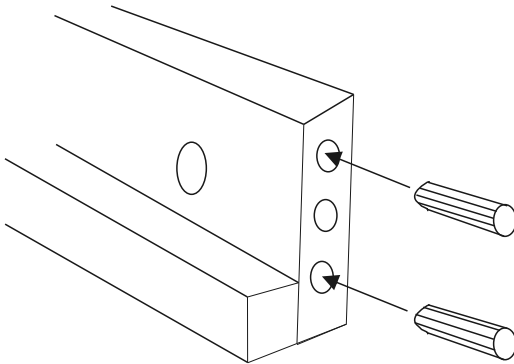

Orientating the bunk bed.

The small side hole on the mattress upper rails are used to fix the ladder to the bunk bed. You can have the ladder fitted on either the left or right side of the bunk bed (viewed facing the long side of the bed). Simply rotate the bed upper bed frame to choose, hole on the left for the LEFT-HAND entrance or hole on the right for the RIGHT-HAND entrance, see images below. The lower bed frame does NOT have holes on the mattress rails and are therefore universal, the ladder simply sits on top of the mattress rail.

For the purposes of this instruction leaflet we will explain the assembly with the ladder on the RIGHT, for LEFT side fitting, simply mirror the actions explained and illustrated.

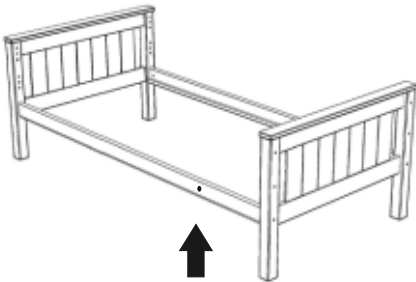

LADDER RIGHT

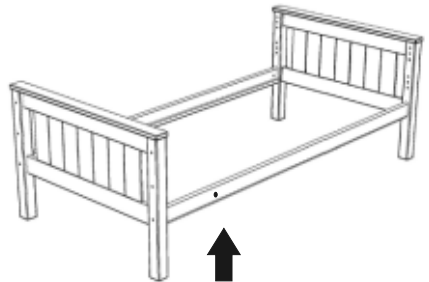

LADDER LEFT

Match BLACK arrows

Building the UPPER bed frame (Two people)

8 x 9cm bolts and 8 x barrel nuts

Front upper mattress rail (LADDER RIGHT) on the front of the bed, fitting the (ladder left) mattress rail along with the rear safety rails at the rear of the bed.

Build the bed with the parts positioned as shown, Align the wooden dowels (fitted in rails) into the holes on the two upper bed ends. Insert a barrel nut into the hole at each end of the rails, allowing it to connect to a long bolt fitted from the outside, rotate to tighten the bed frame

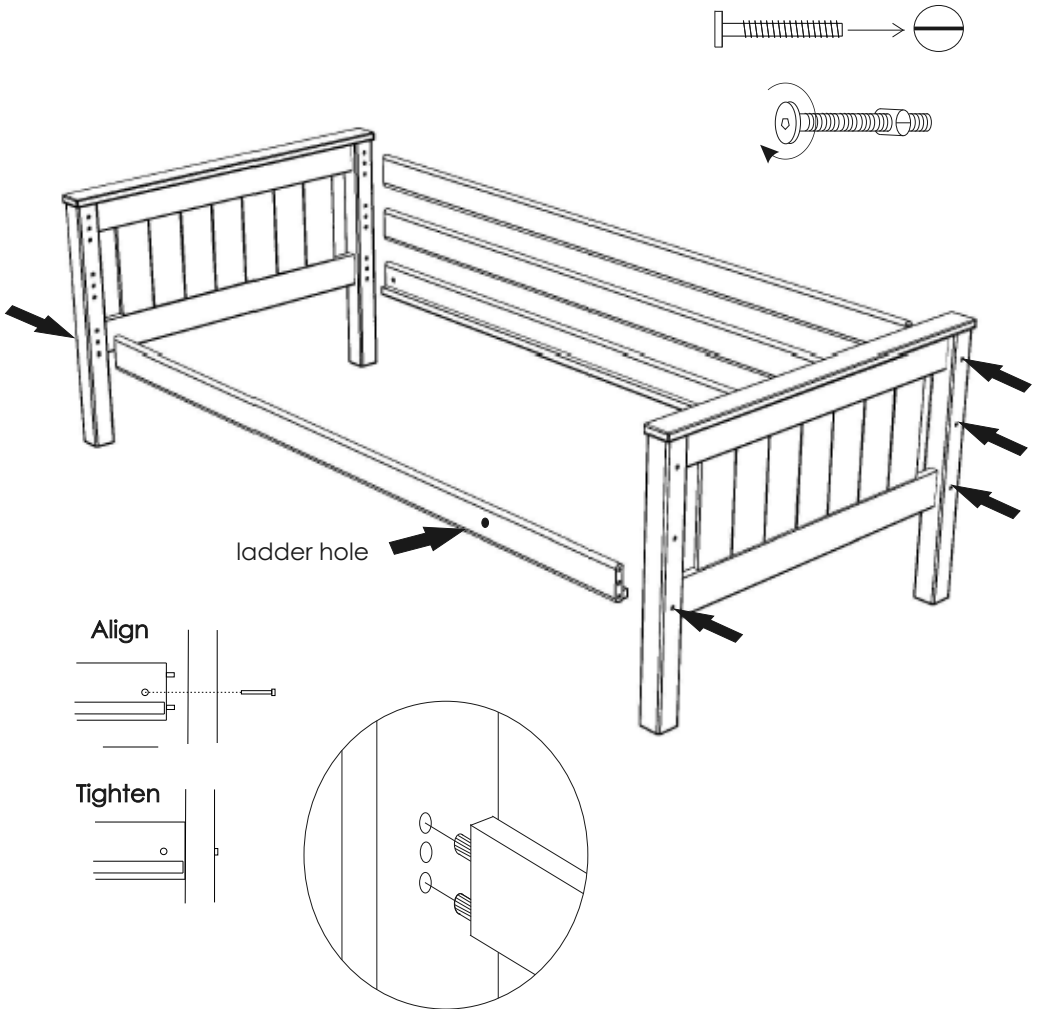

Building the Lower bed frame (Two people)

4 x 9cm bolts and 4 x barrel nuts

No ladder holes on this bed.

Build the bed with the parts positioned as shown, Align the wooden dowels (fitted in rails) into the holes on the two lower bed ends. Insert a barrel nut into the hole at each end of the rails, allowing it to connect to a long bolt fitted from the outside, rotate to tighten the bed frame

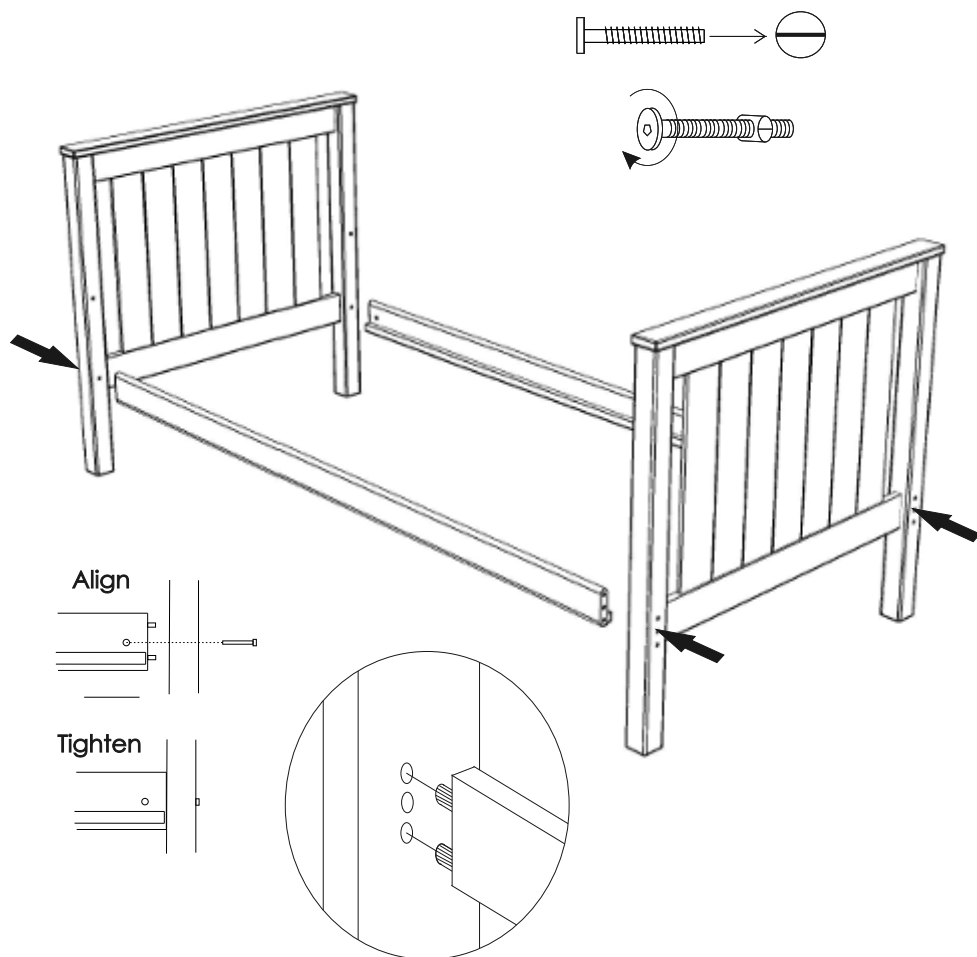

Fit the lower bed mattress base

34 x screws

Carefully roll out the mattress base onto the mattress support pieces fitted on the inside of the mattress rails, webbing on the underside. Starting at one end of the bed, push the end lath tight up against the bed legs and screw in place using the two end holes in the lath. Now push the other end lath tight up against the bed legs at the opposite end of the bed, screwing down to secure. Once both ends of the base are fitted, position yourself at the centre of the bed, now fix each end of the central lath making sure that the lath ends are tight against both mattress rails (some gentle inward pressure will help). Once these three laths are fixed, secure the remaining base laths, screwing down each lath in turn.

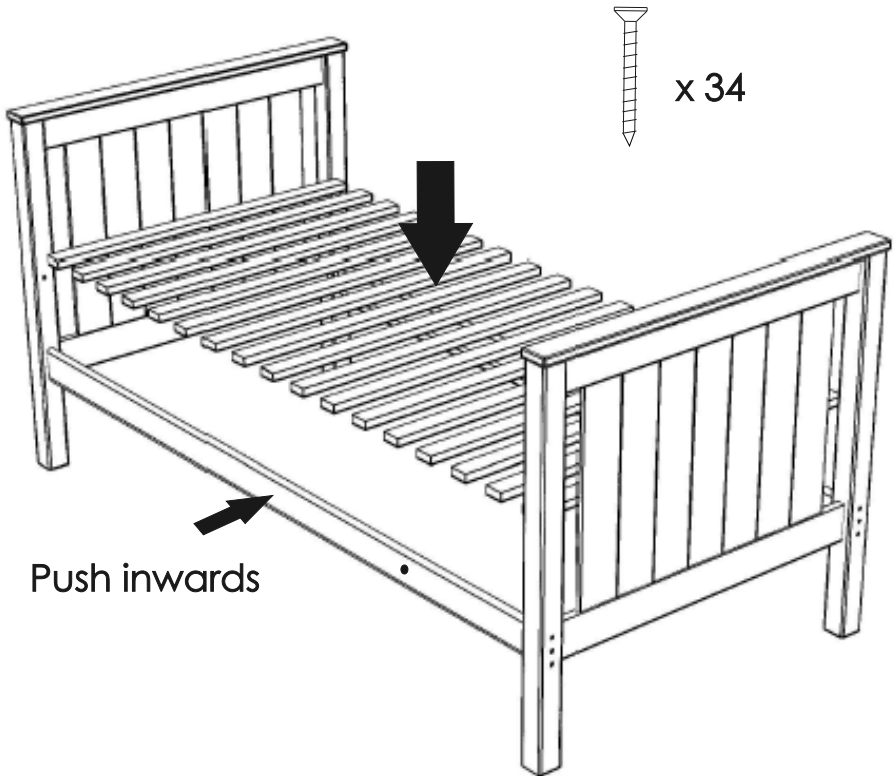

Fit the upper bed mattress base

28 x screws

Carefully roll out the mattress base onto the mattress support pieces fitted on the inside of the mattress rails, webbing on the underside. Starting at one end of the bed, push the end lath tight up against the bed legs and screw in place using the two end holes in the lath. Now push the other end lath tight up against the bed legs at the opposite end of the bed, screwing down to secure. Once both ends of the base are fitted, position yourself at the centre of the bed, now fix each end of the central lath making sure that the lath ends are tight against both mattress rails (some gentle inward pressure will help). Once these three laths are fixed, secure the remaining base laths, screwing down each lath in turn except for the last three laths at the right-hand end of the bed where the ladder is to be fitted, we will return to these laths later in the process.

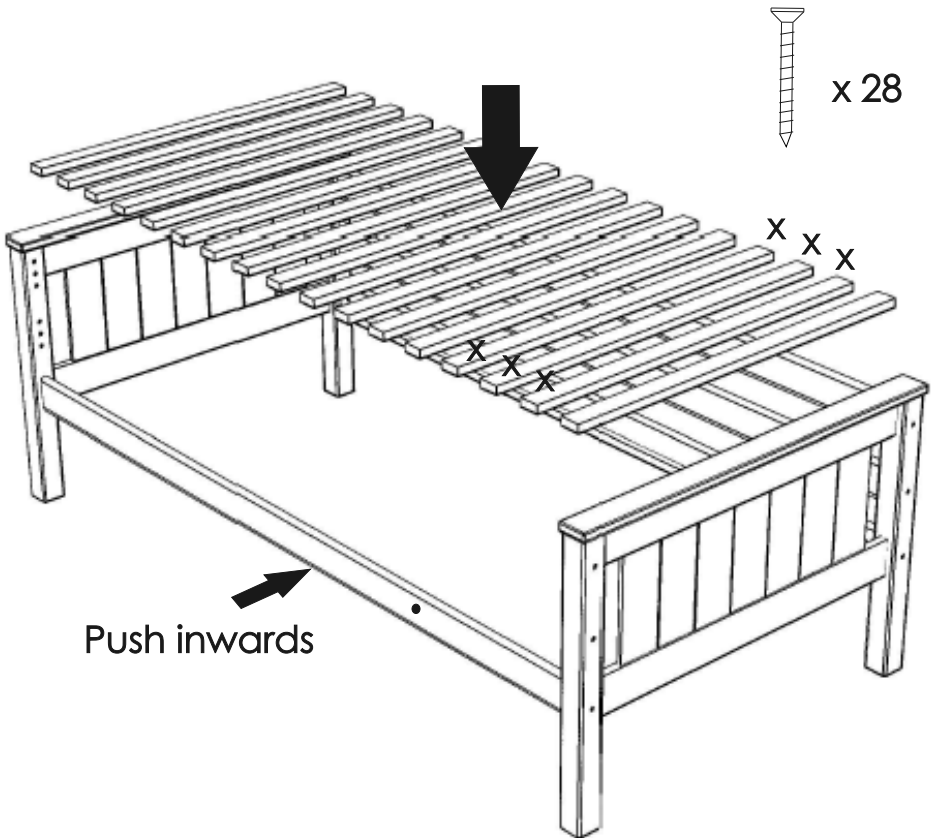

Make the bunk

You need: 4 x large wooden dowels and 8 x 3.5cm screws.

(TWO people to lift the upper bed onto the lower bed).

Drop the 4 wooden dowel into each of the holes in the lower bed capping, pushing each dowel firmly down. Once inserted, lower the upper bed down onto the 4 wooden dowels, checking that each corner leg is in contact with the lower bed capping rail (this can sometimes be a little bit fiddly if the bed is not lowered evenly). Now insert the 8 screws into the securing holes and rotate to secure.

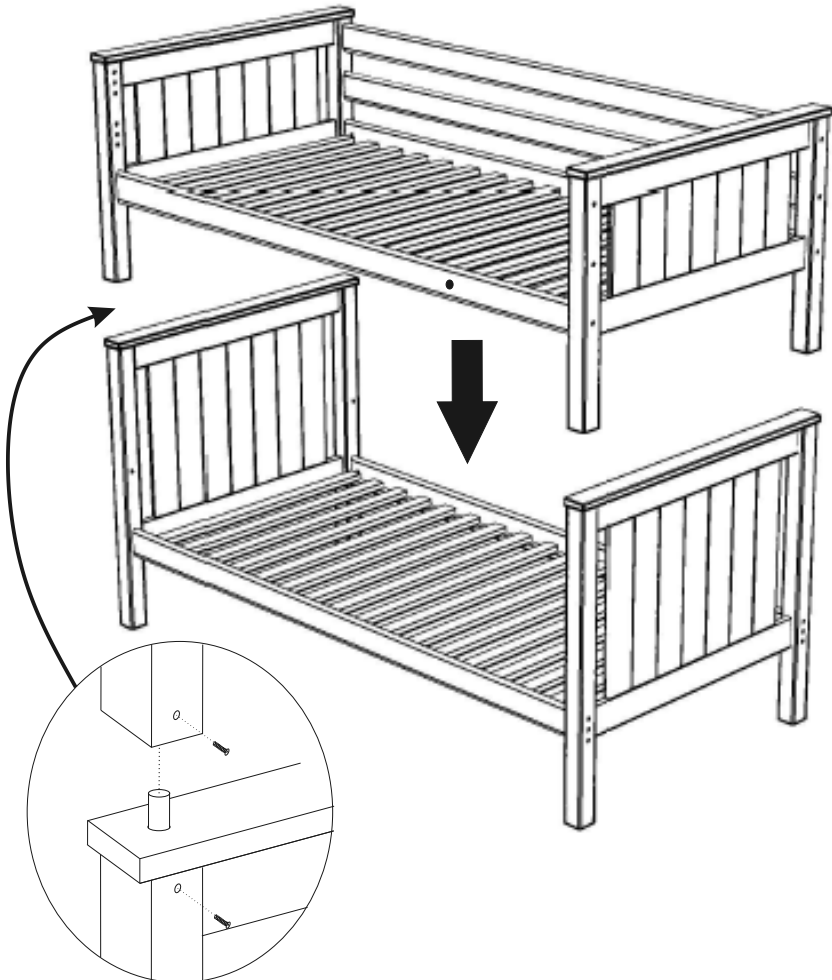

Assemble the ladder frame

You need: 6 x 5cm screw bolts and 12 small wooden dowels
insert 2 wooden dowel into each end of the three ladder treads leaving about 1cm projecting (a small hammer could help if the dowels are tight).
Orientate the parts as shown. The ladder strings as "handed" left and right so take a moment to study the image, making sure that the tread holes are facing inwards.
Align each tread into the holes and connect the tread from the outside side of the strings using two screw bolts. Once all the six screw bolts are connected, tighten them to stiffen up the ladder frame.

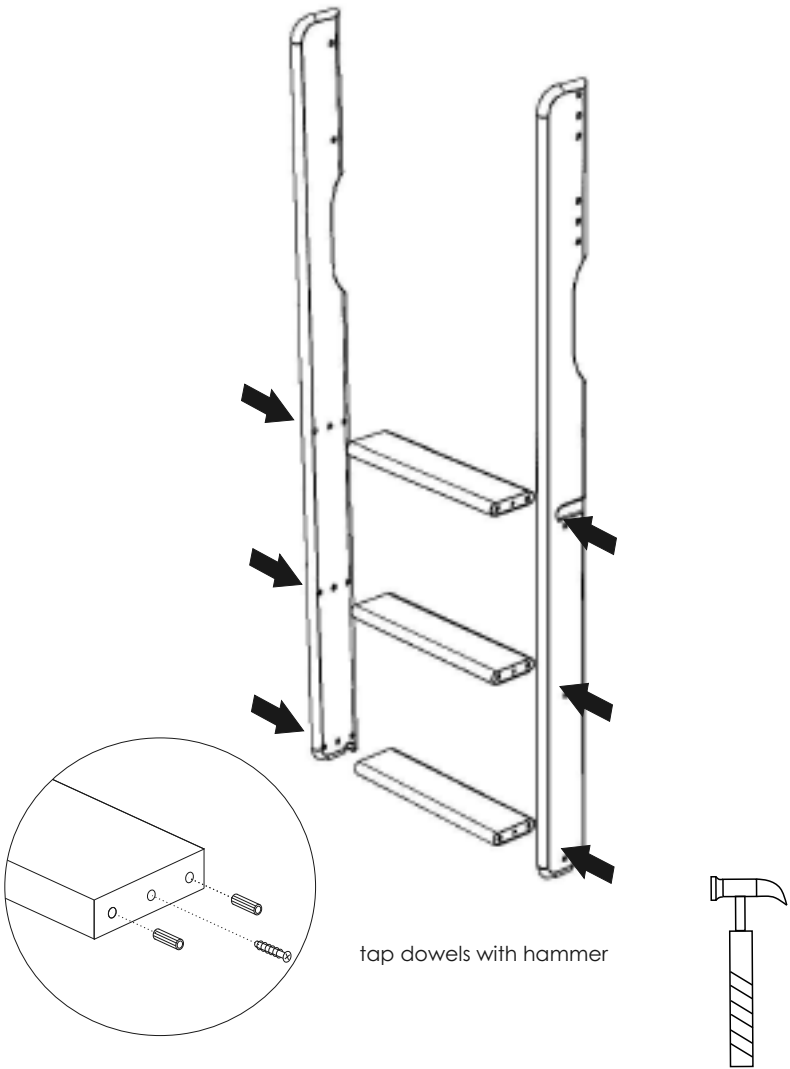

Fix the ladder (ladder right)

2 x 7cm bolts, 2 x 9cm bolts, 4 x barrel nuts, two sleeve nuts, 6 x 3.5cm screws & 1 x 3.5cm bolt

Steps illustrated below.

Lift the ladder onto the lower bed mattress rail, dropping the "notch" over the top edge. Now gently rotate the ladder into the bed until the ladder strings touch the upper bed mattress rail.

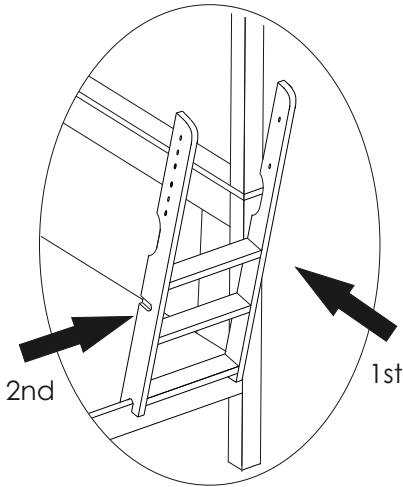

1st pivot ladder inwards
2nd push ladder tight to bed leg

Connect the ladder string

Fix the right-hand ladder string to the bed legs using 2 x 7cm bolts and 2 x sleeve nuts (note that the sleeve nuts can be a tight fit so a gentle tap with the hammer may help).

Connect the ladder to the lower bed leg using the 3.5cm bolt

This can be a bit fiddly so do not tighten up the upper fixings until you have connected the lower 35mm bolt.

It may be that you have to angle the bolts through the part holes to align, and or, gently move the upper bed end as to get ALL the fittings started. Rotate the bolts but do not fully tighten.

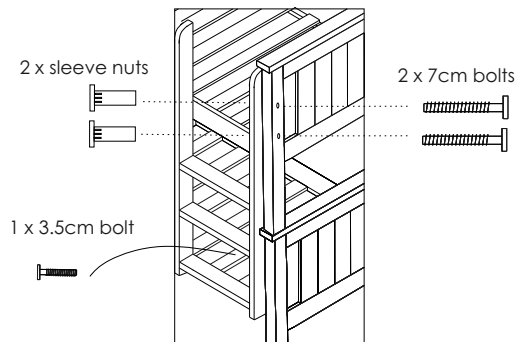

Fit the ladder frame

step explained below

Once these bolts are ALL connected, tighten them to secure as well as tightening the upper mattress rail.

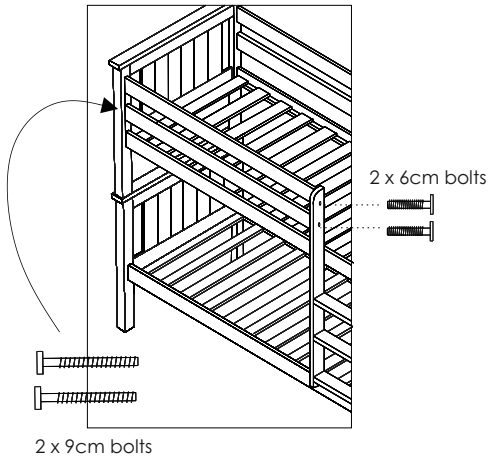

Fix the front safety rails

Slide the two safety rails into the wooden dowel holes located in the upper bed end. Extra space can be gained by loosening the front mattress rail and this will allow the projecting dowels to pass the left-hand ladder string. Once both front safety rails are engaged push the parts together. Now connect the two front safety rails using the bolts shown but do NOT tighten down.

Secure the ladder

1 x screw bolt

Unscrew the right-hand upper bed end lath, allowing the four bed laths to slide inwards. Now connect the left-hand ladder string to the mattress rail using a 5cm screw bolt from the inside, moving the mattress slats to allow access to bolt. Some gentle movement of parts might be required to align the fitting, screw tight the screw bolt. Now refix the end bed lath making sure the bed lath is tight to the bed end. Now fix the three loose laths with the 6 x 3.5cm screws.

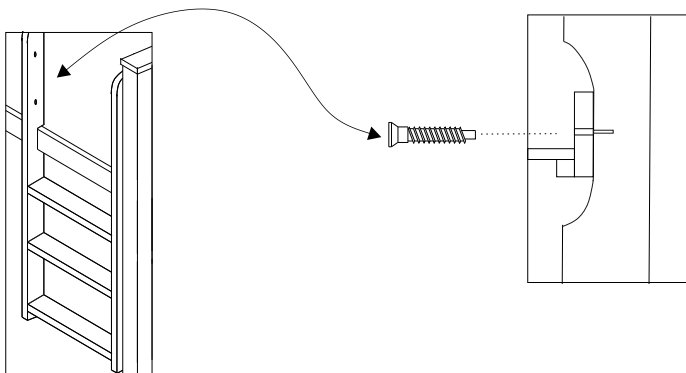

Ladder fittings

Tighten the fittings around the ladder and front safety rails as well as the front upper mattress rail.

Check the bed

Now take a few minutes to look around the bed and tighten all the fittings as well as checking that the bed parts are firmly in place.

Your bed is now assembled.



Fit the mattresses.(two people)

Carefully lift each mattress onto the sleeping surface.
Please use the correct sized mattresses for this product.

PRODUCT SAFETY

The MAXIMUM thickness of the UPPER BUNK mattress is 20cm.

The recommended size of the mattress is 190cm x 91cm (6'3" x 3'0")

Periodically check that all assembly fixings are tightened properly, care should be taken to ensure that no fittings are loose.

Always follow the manufacture`s instructions.

WARNING "High beds and the upper bed of bunk beds are not suitable for children under six years due to the risk injury from falls".

WARNING "Bunk beds and high beds can present a serious risk of injury from strangulation if not used correctly. Never attach or hang items to any part of the bunk bed that are not designed to be used with the bed, for example, but not limited to ropes, strings, cords, hooks, belts and bags"

WARNING "Children can become trapped between the bed and the wall, a roof pitch, the ceiling, adjoining pieces of furniture (e.g. cupboards) and the like. To avoid risk of serious injury the distance between the top safety barrier and the adjoining structure shall not exceed 75mm or shall be more than 230mm.

Moving the bed

Do Not drag or twist the bed.

Lift the bed into place by supporting both the end bed frames and mattress rails, keeping the bed assembly all together and in unison.

Splitting the bunk bed and removing the mattresses will reduce the weight of the product and help assist with repositioning the product.

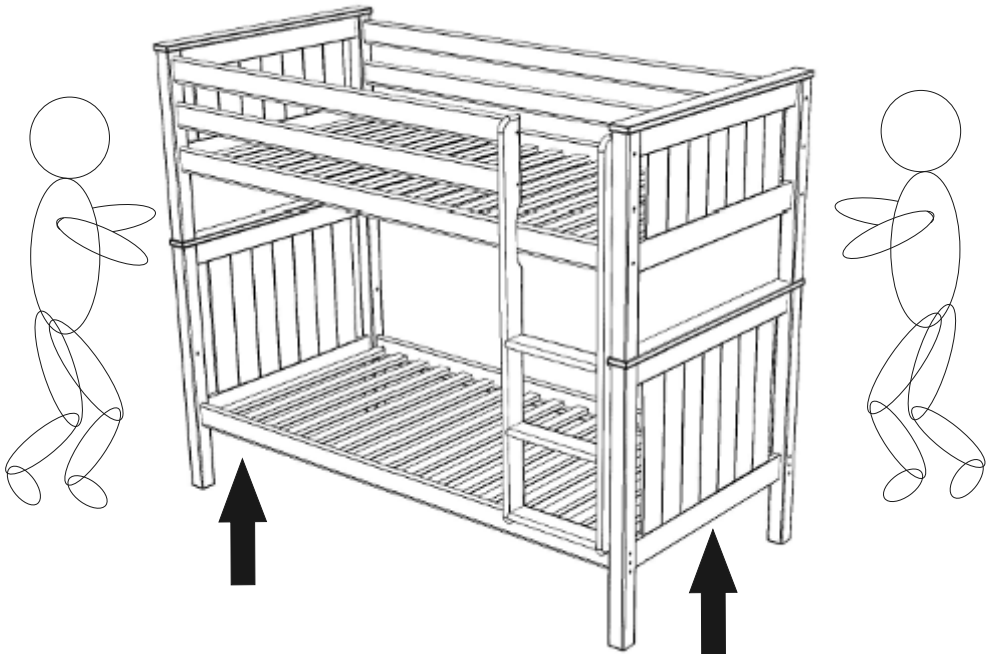

Make two single beds (one lower end and one upper end)

Two people required.

Carefully remove the ladder, front and rear safety frames and mattress bases. Make two sets of single beds using one lower bed end and one upper bed end + two mattress rails and one mattress base. Use previous pages within this instruction leaflet for guidance (no restrictions on holes on the mattress rails for single bed assembly) and mattress base connection.

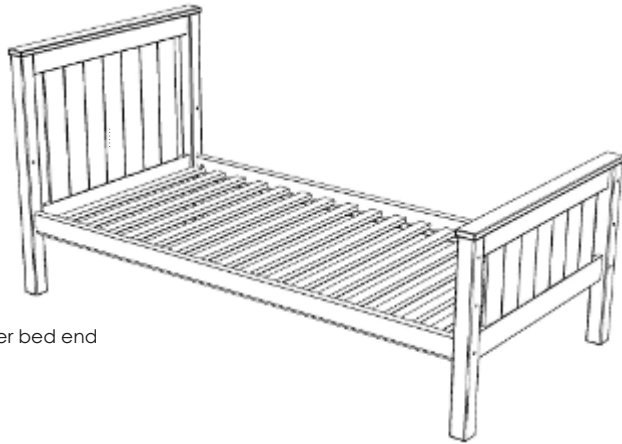

lower bed end

upper bed end

Make toddler / Day style bed (two upper ends)

Two people required.

The upper bed frame complete with the two rear safety rails in-place can be used as a day-bed / toddler style bed.

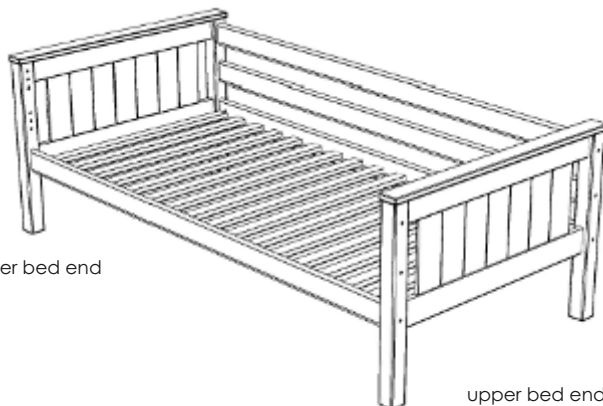

upper bed end

upper bed end

PRODUCT SAFETY

Additional information for single bed use.

Periodically check that all assembly fixings are tightened properly, care should be taken to ensure that no fittings are loose.

Always follow the manufacture's instructions.

Please ensure that good ventilation is maintained within the room in order to keep humidity low and to prevent mould in and around the bed;

WARNING Do not place this child's bed near heat sources, windows and other furniture.

WARNING Do not use this child's bed if any part is broken, torn or missing.

WARNING Hole covers Not suitable for children under 36 months due to choking hazard. The bed can be dismantled for storage or transportation.

Children are likely to play, bounce, jump and climb on beds, therefore the child's bed should not be placed too close to other furniture or windows, blind cords, curtain pulls or other strings or cords and should be placed either tight to any wall or have a gap of 300mm between the wall and the side of the bed.

Additional or replacement parts should be obtained from Little Folks Furniture.

Moving the bed

Do Not drag or twist the bed.

Lift the bed into place by supporting both the end bed frames and mattress rails, keeping the bed assembly all together and in unison. Removing the mattress will help reduce the overall weight of the bed.

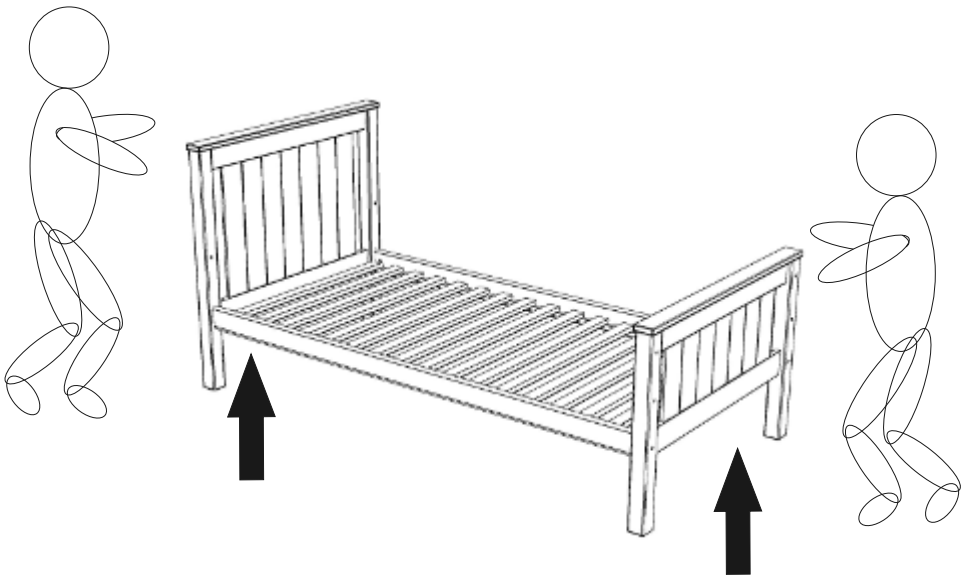

Notes;